

Conexiones del GamakerBot4:

A0(14): -> Tx de placa Bluetooth (BT)

A1(15): ->Rx de placa BT

A4: -> zumbador

D2: -> servo delantero derecho (hombro derecho)

D3: -> servo delantero izdo (hombro izdo)

D4: -> servo trasero derecho (cadera derecha)

D5: -> servo trasero izquierdo (cadera izda)

D6: -> servo giratorio cabeza

D8: -> LED rojo

D9: -> LED amarillo

D10:-> LED verde

D12: -> sensor ultrasónico, pin Echo

D13: -> sensor ultrasónico, pin Trigger

Esquema de conexiones del Arduino Nano:

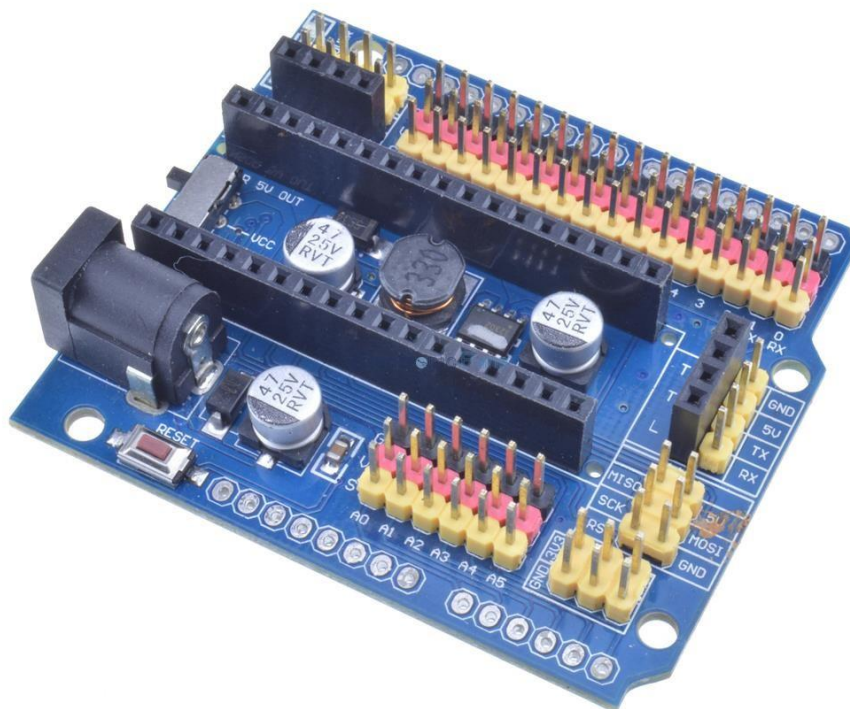
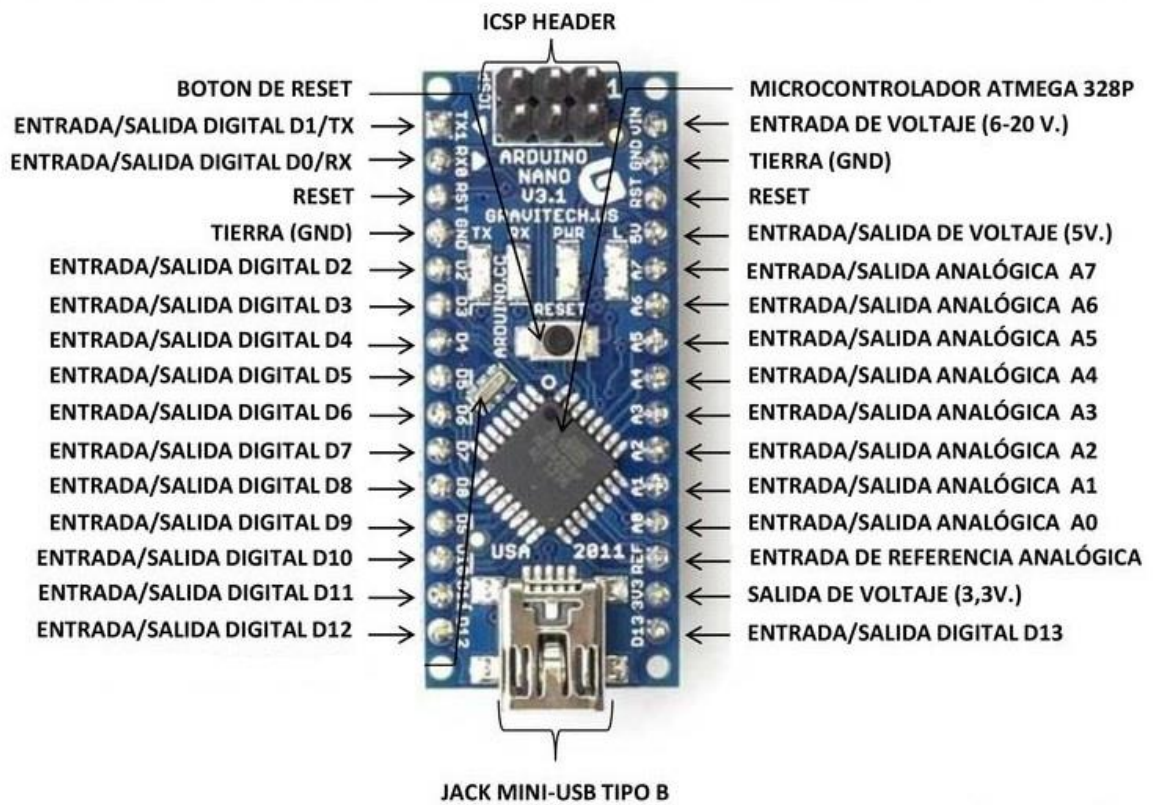

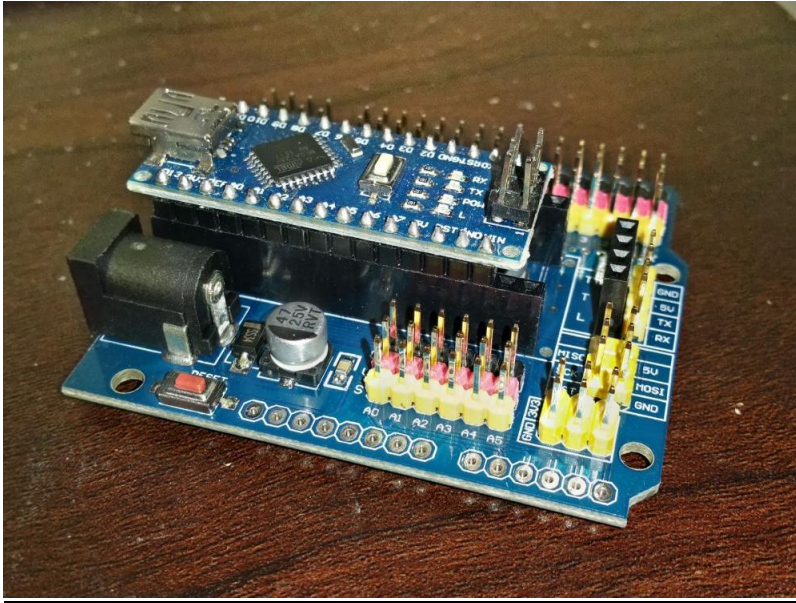

Distribución de teclas en la app Cheetah :

G

F

I

g

f

i

L

l

S

r

R

H

b

j

H

B

J

U

V

W

X

Y

Z